



## Electric engines

For small production runs and retrofits of internal combustion vehicles

Demand for vehicle electrification continues to grow in response to massive environmental challenges. Electrification covers many transport applications and requires versatile electric engines that can be adapted to different technical specifications, keeping costs to a minimum by pooling as many components as possible.

Carnot IFPEN Transports Energie

### Scientific / technological breakthrough

The breakthrough achieved with EREM is the fruit of research conducted by Carnot IFPEN TE into innovative and patented electric motor topologies, enabling progress in two areas. First, very close integration between the electric motor and its electronic control block that enhances performance density (power and torque), thus taking up less space than existing solutions. Second, an innovative solution for cooling both the engine and electronics that facilitates deployment. It can therefore be used in a wide range of applications, such as those with low voltage and high power levels (i.e., 30 kW at 48 V), or others requiring high-torque at high-voltage (up to 400 Nm and 200 kW at 400 V), or very high voltage (800 V), very high torque and power (1500 Nm and >300 kW), requiring specific WBG-type (Wide Band Gap) electronic components for steering.

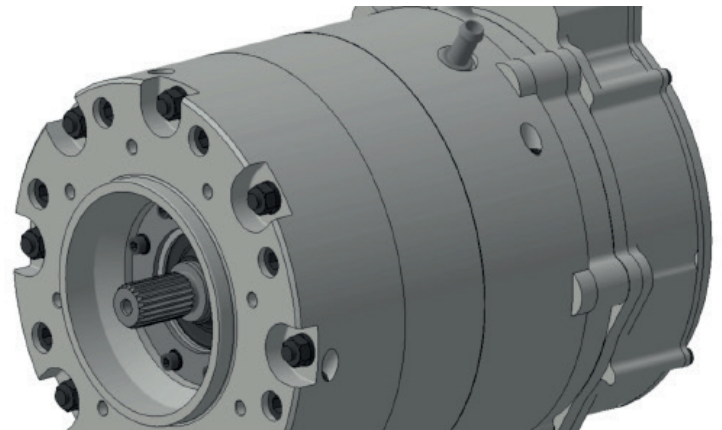
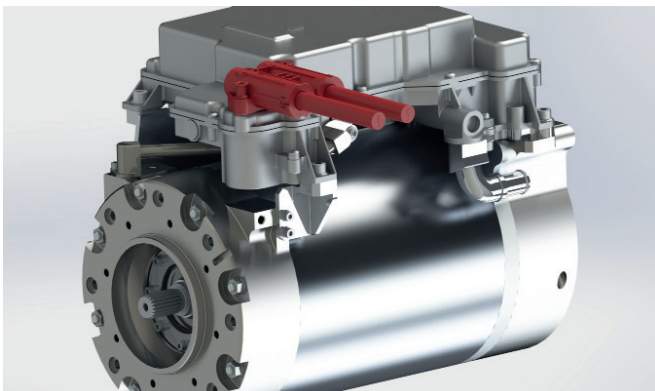

### Competitive advantage for the economic stakeholders

Engine technologies being developed with Carnot IFPEN TE take up less space and may be used in a wide range of applications and there is currently no equivalent offering on the market. These innovative solutions will give EREM an undeniable competitive edge and this has been borne out by the company's prospection within its own ecosystem. EREM will deploy small-scale production runs for these innovative electric engines in France.

### Partnership

- EREM is a mid-sized company specialised in the production and maintenance of custom-built engines for customers both inside and outside France for the past 30 years.